

Ultrasonic Cleaner Project Plan

Project 09

Client:
R.E. Patterson, III

Faculty Advisors:
Dr. John Lamont
R.E. Patterson, III

Team Members:
Daniel Wilcox, CprE
Brad Aswegan, CprE
Andrew Whitcomb, EE
Kenneth Uhlenkamp, EE

REPORT DISCLAIMER NOTICE

DISCLAIMER: This document was developed as a part of the requirements of an electrical and computer engineering course at Iowa State University, Ames, Iowa. This document does not constitute a professional engineering design or a professional land surveying document. Although the information is intended to be accurate, the associated students, faculty, and Iowa State University make no claims, promises, or guarantees about the accuracy, completeness, quality, or adequacy of the information. The user of this document shall ensure that any such use does not violate any laws with regard to professional licensing and certification requirements. This use includes any work resulting from this student-prepared document that is required to be under the responsible charge of a licensed engineer or surveyor. This document is copyrighted by the students who produced this document and the associated faculty advisors. No part may be reproduced without the written permission of the senior design course coordinator.

October 5, 2004

Table of Contents

List of Figures	ii
List of Tables	iii
List of Definitions.....	iv
1.0 Introduction	1
1.1 Abstract.....	1
1.2 Acknowledgement.....	1
1.3 Problem Statement.....	1
1.4 Operating Environment.....	2
1.5 Intended Users and Uses	2
1.6 Assumptions and Limitations	2
1.7 Expected End Product and Other Deliverables.....	3
2.0 Proposed Approach	4
2.1 Functional Requirements	4
2.2 Constraints.....	5
2.3 Technology Considerations	5
2.4 Technical Approach Considerations	6
2.5 Testing Requirements Considerations.....	8
2.6 Security Considerations	9
2.7 Safety Considerations.....	9
2.8 Intellectual Property Considerations	9
2.9 Commercialization Considerations.....	10
2.10 Possible Risks and Risk Management.....	10
2.11 Project Proposed Milestones and Evaluation Criteria.....	11
2.12 Project Tracking Procedures.....	11
3.0 Statement of Work.....	12
3.1 Task 1 – Problem Definition.....	12
3.2 Task 2 – Technology Considerations and Selections	12
3.3 Task 3 – End Product Design	14
3.4 Task 4 – End-Product Prototype Testing and Implementation.....	19
3.5 Task 5 – End-Product Documentation	19
3.6 Task 6 - End-Product Demonstration.....	20
3.7 Task 7 – Project Reporting	20
4.0 Estimated Resources	21
5.0 Schedules	23
5.1 Deliverables Schedule	23
5.2 Project Schedule.....	24
6.0 Project Team Information	26
7.0 Summary	27
8.0 References	28

Figures

[Figure 1]	Example of an Ultrasonic Record Cleaner	1
[Figure 2]	Effectiveness of particle removal relative to frequency	5
[Figure 3]	Microscopic cavitation bubble due to ultrasonic vibration.....	8
[Figure 4]	Initial Record Mounting and Spindle Design	14
[Figure 5]	Initial Tank Design.....	15
[Figure 6]	Placement of Transducers	16
[Figure 7]	8083 Waveform Generator Integrated Circuit.....	16
[Figure 8]	Function Generator circuit utilizing a single 8083 IC	17
[Figure 9]	Simple Bridge Rectifier.....	19
[Figure 10]	Fall 04 Deliverables Schedule.....	23
[Figure 11]	Spring 05 Deliverables Schedule	23
[Figure 12]	Fall 04 Project Schedule	24
[Figure 13]	Spring 05 Project Schedule.....	25

Tables

[Table 1]	Estimated Personnel Effort Requirements	21
[Table 2]	Other Required Resources.....	21
[Table 3]	Original Project Estimated Costs.....	22

List of Definitions

Audiophile	A person who is enthusiastic about high-fidelity sound reproduction
Cavitation	The formation of partial vacuums in a liquid by a swiftly moving solid body (as a propeller) or by high-intensity sound waves
I/O	This abbreviation refers to any operation in a computer where data is transferred in or out of the computer.
IC	(Integrated Circuit) A tiny complex of electronic components and their connections that is produced in or on a small slice of material
PCB	(Printed Circuit Board) The complete path of an electric current including usually the source of electric energy on an assemblage of electronic elements
Transducer	A device that is actuated by power from one system and supplies power usually in another form to a second system
Vinyl Records	Something on which sound has been recorded; specifically: a disc with a spiral groove carrying recorded sound for phonograph reproduction
Ultrasonic	having a frequency above the human ear's audibility limit of about 20,000 hertz -- used of waves and vibrations

1.1 Abstract

A minority within the audio consumer market preferring vinyl records to digital audio may often have trouble finding safe, thorough cleaning devices. Cleaning is also a very tedious process which requires care. One such solution may be an ultrasonic cleaning device for a safe, automated way to clean vinyl records. The drawback to this technology is the extreme expense of such a system. This project team endeavors to design an effective ultrasonic cleaning device for less than commercial ultrasonic cleaners. See Figure 1 for an example of an ultrasonic record cleaner. This will be accomplished by partially submerging a rotating vinyl record in a cleaning solution agitated by an ultrasonic transducer. A working design will result in an ultrasonic cleaner at a fraction of the cost of commercial units available today.

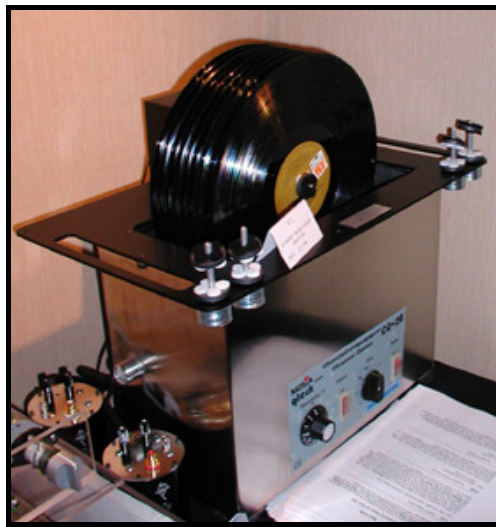

Example of an Ultrasonic Record Cleaner Prototype by Bent Audio^[1]
[Figure 1]

1.2 Acknowledgement

The members of this project would like to thank Iowa State Professors Ralph Patterson and John Lamont for providing technical expertise, funding, and various pieces of necessary equipment.

1.3 Problem Statement

The problem to be solved by the design team is to build an efficient and inexpensive ultrasonic record cleaner. The cleaner must be able to thoroughly clean one or more records effectively. The apparatus will include a container of specially-formulated cleaning solution agitated by an ultrasonic transducer through which a partially-submerged record will rotate. The proper cleaning solution must be determined so as not to do any damage to the vinyl, and the label must be kept dry. A motor will be used to continuously rotate the record. A system for raising and lowering the record(s) is necessary as well. A filtering system will keep the solution clean enough for extended use. Time permitting, an automated system for detecting record cleanliness will be added, as well as a

timer which may be programmed by the user. It may also be possible to adapt the Ultrasonic Cleaner for other uses such as jewelry or denture cleaning.

In order to accomplish such a task, it will be necessary to originally construct the raising and lowering system out of a non-automated weighted arm. The final system may contain an actuator or a screw-driven motor. Either suction or positive pressure through the suction cups will protect the record label. A system of springs and spacers may make it possible to clean as many as ten records at once. The rotating of the record will be accomplished by an AC or DC motor rotating the rod the records are suspended from. A transformer and full wave rectifier will be necessary to convert electricity from an AC source, and a signal generator will be needed to power the transducer. The transducer may be mounted on the side, bottom, or outside the tank depending on preliminary testing. The solution used will be a commercial cleaner to be determined after extensive research. To save on cost, a filtration system will more than likely be used to preserve the purity of the cleaning solution.

1.4 Operating Environment

The recommended environment for the ultrasonic cleaner is a sheltered area lacking extreme temperatures or large fluctuations in temperatures. The area of use should also be free of dust. Operation in a poor environment may reduce effectiveness by preventing cleaning solution cavitations or by contaminating the cleaning solution. The ultrasonic cleaner is not made to be a portable device and should rest on a sturdy, level surface. The area of use should also include a 110V AC outlet, which is necessary for operation.

1.5 Intended Users and Uses

This ultrasonic cleaner is designed for use by the audiophile market interested in high-quality sound reproduction. The ultrasonic cleaner is designed for use by adults 18 and older. Though cleaning system maintenance is not overly complex and can be accomplished by the average adult, some care must be taken when handling or disposing of the cleaning solution. This product should be kept away from children, since cleaning solution temperatures may reach 150°F and may be harmful if swallowed.

This cleaner should be used for the purpose of removing small particles of dirt and dust from records. Other cleaning uses may be possible but are not recommended. The ultrasonic cleaner should not be used for records with large amounts of visible dirt because such a use may degrade cleaning performance.

1.6 Assumptions and Limitations

In order to understand the scope of the project, some assumptions must be made. Due to various specified and practical constraints, there are also a few notable limitations of the ultrasonic cleaner.

Assumptions

Assumptions are the result of decisions that can be made by the team and affect the end-product design and implementation. Here are the current assumptions for the ultrasonic record cleaning project.

- A limited number of records may be cleaned at the same time.
- The project will not be supported with a manual outside of the U.S.
- The ultrasonic cleaner is to be used by adults 18 and older
- The cleaning solution will not permanently alter the record
- The diameter of the center of each record is the same.
- The diameter of the labels will be smaller than that of an average 33rpm record.
- The cleaner will not harm the user.

Limitations

Limitations are the result of things over which the team has no control, but must consider in its end-product design and implementation. Here are the current limitations for the ultrasonic cleaning project.

- This product is limited to indoor use.
- The cleaner will only be able to clean three types of records- 78rpm, 45rpm, and 33rpm.
- Scratches and other surface defects cannot be removed.
- The label must remain free of moisture or any other harmful agent.
- The project's supplies will not exceed \$260.
- The cleaner will be powered by a 110V electrical outlet.
- The project must be completed by May 2005.

1.7 Expected End Product

The product to be delivered is a working AC-powered ultrasonic record cleaner in a single commercial package. A short manual will also be delivered at the same time as the working product. This manual will include safety information, basic operation procedures, and intended uses. The ultrasonic cleaner will have a maximum size of 2'x2'x2', a maximum weight of fifty pounds, and a maximum power consumption of 500 watts.

2.0 Proposed Approach

The proposed approach to the project consists of the functional requirements, project constraints, various considerations, possible risks and risk management, proposed milestones and evaluation criteria, and project tracking procedures. The considerations are technology, technical approach, testing requirements, security, safety, intellectual property rights, and commercialization.

2.1 Functional Requirements

For the project to be completed successfully it must meet the functional requirement outline. The functional requirements for the project are as follows:

- Clean vinyl records with ultrasonic technology
The cleaning process will remove dirt and dust particles from the audio grooves of the vinyl platter to increase the sound quality of playback.
- Unit will accommodate different record sizes and materials
The cleaning unit will be versatile enough to support at least 33's, 45's, and 78's and if separate solutions are required for different chemical composition of records, the unit will accommodate them accordingly.
- Clean multiple records
To save time the machine will clean as many records simultaneously as possible.
- Unit will be as automated as possible
Once the cleaning unit has been loaded with records ready for cleaning it will dip the record(s) into cleaning solution. After the record(s) are lowered into the solution the machine will commence the ultrasonic cleaning cycle. When the record(s) have completed the cleaning process the unit will extract records from solution and dry them. Finally a done indicator will report cleaning process complete.
- System Filtration
A filtration system will be implemented to keep the ultrasonic cleaning solution as clean as possible.
- Detection of cleanliness
A system will be implemented that monitors how clean the record(s) are by detecting the amount of dirt in the water. A filtration device will be used to keep the water clean and when it is no longer filtering out particles in the water the cleaning process will be terminated.
- Power
Unit will be powered by a conventional 3-prong 60-cycle 115V power cord.

2.2 Constraints

Due to limitations on abrasiveness, size, and weight constraints will affect the final form of the end product. Constraints on the plan are as follows:

- Physical harm from dipping/cleaning mechanism and automation will not occur. There shall be no chemical breakdown of Vinyl due to cleaning solution or destruction of label from contacting the cleaning solution. Cleaning will not decrease the quality of the recording
- Existing physical defects to a record's surface (e.g. scratches) will not be repaired by the unit.
- Unit shall not exceed functional home-use size: 2'x2'x2'.
- Unit should be moveable with a maximum weight of 50 lbs.
- There is no limit on time; the unit should take as long as needed for the best cleaning of the records. Max power during operation is 500 watts.

2.3 Technology Considerations

Since adaptation of current technology to provide a low-cost version of a currently expensive product is required, it is important to note the areas of technology that will be emphasized.

- Ultrasonic technology
 - The size and number of transducers must be high enough to cover the tank with the ultrasonic signal to achieve optimal cavitation within the entire amount of solution. As a result of the cavitation, the ultrasonic cleaning solution may reach temperatures of 150°F and caution should be taken to shield the user from exposure. A signal generator will provide the signal to be used by the transducers. This must be implemented using the optimal cleaning frequency(s) found in frequency testing. Figure 2 shows how different frequencies clean different particles of dirt.

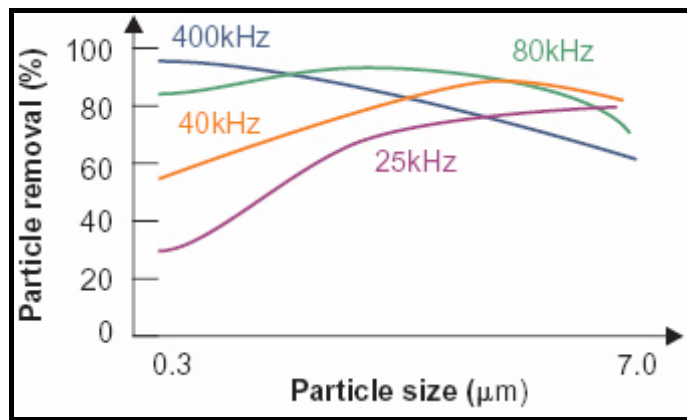

Effectiveness of particle removal relative to frequency courtesy of IC Knowledge LLC^[2]
[Figure 2]

- **Cleaning Solution**

Proper cleaning solution is required for optimal results in playback quality. Different solutions are available for use on different materials ranging from soft plastics to processed metals and alloys. Research is needed to determine an effective solvent for the cleaning bath due to the composition of the plastic in the records. If a chemical solution is not feasible, then distilled/de-ionized water is to be considered.
- **Filtration System**

A filtration system is needed to keep the cleaning solution free of particles which could recollect on the record(s). The filtration system will also allow for repeated uses without the user having to replace the solution. An automated checking system may show the status of the solution and indicate if it needs to be changed.
- **Quantity of records to be cleaned:**

Cleaning individual records would not require a large unit and may result in a higher-quality removal of particles. The user, however, would have to load/unload each platter individually thus increasing the required time to process a large number of records. Testing is required to determine if multiple records can be cleaned at one time. The cleaning of up to 10 records would be advantageous to the user since a larger number of records could be cleaned in a shorter amount of time, although the loading/unloading time for each cleaning process is increased.
- **Automation**

Automation must be simple and easy-to-use. The automation should include indicators/displays as to which step it is through the cleaning process. User interface including power and control input through buttons, etc.

2.4 Technical Approach Considerations

It is important to focus on the technological approaches available to the project plan since the requirements include the use of specific technology.

- **Ultrasonic Technology**

The frequency is to be taken into consideration through testing. A certain frequency may result in a better cleaning of the record. Frequencies to be considered are in the 25 kHz - 100 kHz range. A modulating frequency may be considered so that a range of cavitation is possible. This should be tested to see if it is both feasible and worthwhile. The complexity and component cost of the sonic transducers makes their construction prohibitive. Commercial units must be found, either for purchase or donation from a sponsor.

A signal generator is required to both power and feed the signal to the transducers. Its design will be impacted by the results of initial frequency and modulation testing. The cost of a commercial generation unit (e.g. function generators, etc) should be examined to see if there is a more effective alternative to construction a signal generator/power system for the transducers.

- **Cleaning Solution**

The cleaning liquid may be of specialized ultrasonic cleaning solution or distilled / de-ionized water. Prices are far from prohibitive for most specialized solutions come in concentrate, but care must be taken with some chemicals which are harmful and cannot be disposed of easily. Another chemical component could be added to the solution which would cause the solution to sheet off of the record which would aid in drying.

- **Filtration System**

A filtration system could be used to ensure the cleaning solution is free of particles. Technology options include but are not limited to: aquarium filters, electrostatic filters, and skimming filters.

- **Quantity of Records the be cleaned**

The tank size and number of transducers required to cover the tank will depend directly on the max number of records to be cleaned at one time; more records require a large tank which will require more/larger transducers to cavitate the solution effectively.

- **Automation**

A microprocessor is required for the control of the system. A microprocessor and interface for the system must be selected and designed for the designated functions:

- i. Dipping: Lower arm with records into cleaning bath with depth dependant upon size of loaded records (deeper for 33's as opposed to 45's)
- ii. Cleaning: Handle rotation of record spindle, signal generator triggering, and timing considerations.
- iii. Extraction and Drying: Raise records from bath to air dry or activate drying system if implemented.
- iv. Done: Activate signal the cleaning process is complete.

Control must be interruptible by user at any time during the entire process and must not present a danger to the user (e.g. splashing of cleaning fluid from record insertion, flying record arm, etc.).

2.5 Testing Requirements

Testing will be required to determine the optimal design of the ultrasonic cleaner's transducers, tank size, tank material, solution and finally end-product testing.

- Research Testing

Frequencies between 25 kHz – 100 kHz should be tested on medium to light-dirty records in order to find the best mean frequency for ultrasonic cleaning. A high frequency may cause the cavitation bubbles to be smaller and thus clean out smaller particles missed by larger cavitation. Figure 3 shows what a cavitation in water looks like.

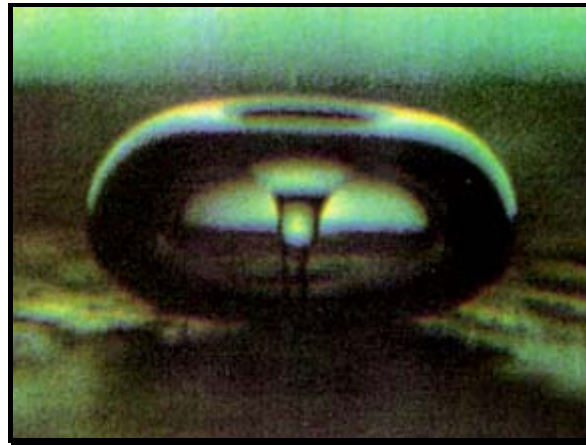

Microscopic cavitation bubble due to ultrasonic vibration courtesy of National Center for Physical Acoustics, University of Mississippi.^[3]

[Figure 3]

Playback quality is the deciding factor between different frequency approaches. The results will help determine the optimal signal needed for the design of the signal generator. Certain frequencies may be better for certain areas of the record. Since the grooves are spaced differently due to the angular spin of the record, smaller frequencies may clean the closer grooves better while vice versa. Modulating a frequency sweep may provide the best solution or could potentially harm the record. Testing is required to determine if this approach is feasible.

Testing is needed to see if multiple records can be cleaned to an acceptable degree at a time. Playback quality is the deciding factor between different approaches. The results will help determine the number of records to be cleaned at one time and the size of the tank.

Testing of the many different solution options is required. Testing will be conducted to find the solution that does the best job of cleaning the record as well as not harm the record.

- End Product Testing
Unit must perform all automated processes correctly without requiring intervention from user. Records should not be harmed in any way; physically, chemically, or damage to the label. Recorded playback quality of cleaned records should be acceptable to client.

2.6 Security Considerations

If commercialization of the end-product, either by client or project-team, is considered, then care should be taken to maintain privacy on design of signal generator and control system/software. This is the area that will provide the lower cost of the end-product as opposed to current products of similar design. Overall design is patterned after available technology and security for the design of the tank, spindle arm, and outward appearance is not needed.

2.7 Safety Considerations

Care must be taken to avoid danger during project development to the team-members as well as to the end-product user by highlighting safety considerations.

- Unit must not harm user or present a danger in its automated movement.
Spindle must not release records or swing/spin dangerously. Rotation of records should not splash cleaning solution out of bath area during the cleaning process.
- Unit should be balanced to avoid risk of collapse.
- Cleaning solution should not come in contact with user.
During cavitation, solution could reach 150°F. If harmful chemical solution is used, proper cleanup and MSDS materials should be provided.
- Electronics shall be shielded from the user to prevent electric shock.

2.8 Intellectual Property Considerations

Retention of intellectual property rights through references and acknowledgement is important to the credibility of the project and those involved. Property rights are also associated with the design of project to the team-member's involved and care must be taken to preserve these rights to the intellectual owner.

- Care will be taken to reference all outside sources of information on technologies which will be used for research and design aids throughout all project documentation.
- The design of the signal generator and control system/software should be protected if commercialization of the product is desired.

- If a team member leaves, his/her input is not taken from the product design and his/her property right is retained, but not at cost of the product design and implementation.

2.9 Commercialization Considerations

The end-product could provide a low-cost, better-quality solution to ultrasonic record cleaners on the market today. The basic ultrasonic technology is readily available, but it will be the research and testing for the construction of the signal generator that will set the projects design apart from current technology. Ultrasonic cleaning was originally produced to sterilized medical instruments and deep clean industrial components. The adaptation and refinement for the cleaning of vinyl records would make the end-product much more desirable. The end-product's automated system would make use of the unit easier than current devices and provide quality control that is also not available.

2.10 Possible Risks and Risk Management

Problems may/will occur during project development. Foreseeable problems must be identified and contingencies drafted so the progress of the project will not be significantly impeded upon the occurrence of one of these hang-ups.

- If a technical approach is not feasible then an alternative must be identified and applied. For example, if testing and research determines the ultrasonic approach to cleaning vinyl records will not work effectively or at all, a more conventional approach utilizing brushes may be pursued.
- If a cost-effective transducer that can handle a sweeping signal cannot be found, then a single frequency may have to be an option.
- If a process results in the destruction of the record(s) which are to be cleaned, then it must be changed and documented to avoid this problem.
- If specialized ultrasonic cleaning solutions are used, but results in harm to record(s) and/or to operators, then another solution must be chosen.
- Extensive documentation as to the research, design, testing, and other aspects of the project will be kept in personal logbooks as well as team reports to provide library of materials in case a team member leaves.
- Detailed knowledge in ultrasonic technology, cleaning solution, and impact of ultrasonic cleaning on vinyl is lacking in all team-members. Extensive research and testing is needed for a feasible and successful design.

- If a team member is lost a new member shall be appointed and be informed of the teams current state and tasks that need to be accomplished.
- Cost must be kept low as it is a main requirement and available funds for the project are low. If possible, required components should be sponsored or donated as opposed to commercially purchased.
- Deadlines must be observed by all team members to avoid a loss schedule time and deliverables to client.

2.11 Project Milestones and Evaluation Criteria

Milestone and evaluation criteria must be stated to provide bounds to the progress of project development.

- Proposed milestones are: specifying requirements, design, implementation, and testing.
- The proposed milestones will be evaluated based on the following categories: better than expected, gone as expected, almost met, didn't meet, or didn't attempt. To be considered a success, the project must work, completed on time, free of bugs, below or at budget, and meets requirements. Also, the project must be able to be reduplicated with the exact same results by another group upon completion of the project.

2.12 Project Tracking Procedures

It is important to identify what measures are to be taken to keep product development on time so as to avoid pitfalls.

- The team must stay informed within itself as well as with the client to keep abreast of changes to design, requirements, budget, etc. Weekly meetings are planned with advisors and the client for face-to-face progress reports. A weekly email also relates progress and work done. The team members meet weekly to relay information and assign tasks. Extra meetings may be assigned in order to meet deadlines and deal with unexpected developments.
- The team must complete project requirements on time in order to keep entire project development on schedule.
- The team must stay on schedule and submit deliverables by listed deadlines.
- The project must be kept on or below budget through careful component selection and possible donation or sponsorship.

3.0 Statement of Work

The design, implementation, testing, and demonstration of the project must be defined in detail in order for both the client and the team to understand what is to be done throughout project development.

3.1 Task 1 – Problem Definition

Design of an ultrasonic record cleaner for a cost less than that of a commercially comparable unit currently available.

Task 1 Objective: Find out exactly what is to be accomplished by this project.

Task 1 Approach: Definition: Create a high quality ultrasonic record cleaner that is as automated as possible, cleans as good as commercially available units, takes as long as it needs to complete the job, and costs a fraction of the commercial units.

Task 1 Expected Results: The results from this will be the best record cleaner for your money.

3.2 Task 2 – Technology Considerations and Selections

The project requires the adaptation of ultrasonic and integrated circuit technology.

Task 2 Objective: Implement the available technologies into the project and refine their capabilities to accomplish the project requirements.

Task 2 Approach: Assess each area of technology that needs to be implemented and provide a viable solution.

Subtask 2a – Ultrasonic Frequency

The frequency used for ultrasonic cleaning directly affects its performance of the cleaning and must be carefully chosen. A high frequency causes much smaller cavitation bubbles which allow smaller surfaces and holes to be cleaned, but at a loss of power.^[4] A lower frequency cannot clean as minute an area as effectively, but will provide higher cleaning power over all. For example, a frequency of 40 kHz will provide 10 times more power than a frequency of 80 kHz; the grooves on a 45 are larger than those on a 33 and lower frequency may be more effective.

The noise generated by the cleaning process is directly affected by frequency. The ultrasonic spectrum is above the human hearing range and runs from 25 to 100 kHz. The closer the frequency is to 25 kHz, the more noticeable and uncomfortable the signal. An ultra-high frequency close to 100 kHz will be undetectable.

Transducers designed for use with a lower frequency are stronger can handle more power overall as compared to high frequency models. This may be desirable in order to increase the end-products effective lifetime.^[4]

Testing and research are required to find the optimum common ground between a high and low frequency.

Subtask 2b – Frequency Modulation

More than a single frequency may be needed to effectively clean a record since, as the audio grooves spiral inward, the distance between them shrinks and they grow smaller. A lower frequency would clean the outward edges effectively, but not be as useful towards the center and vice versa. Modulation between these frequencies might be the best option to achieve the best results from both approaches. Testing and research are needed to determine if this approach is feasible and useful.

Subtask 2c – Integrated Circuit Approach

Integrated circuits are required for the control system and signal generator. They must be applicable to the functions required of them and be cost-effective. The microcontroller for the overall control system needs only to interface with simple I/O and voltage controlled devices and thus not need to be very complex in its own right. It must be easily programmable and have enough memory for the program written for it. The selection will be based on research and the observations of others familiar with available microcontrollers, such as previous senior design teams.

The signal generator may be implemented through the use of a waveform generator integrated circuit in order to make the design more flexible and low-cost. Signal frequency, waveforms (sine, triangle, etc), gain, and modulation for example can be set through this one chip, thus eliminating extra circuitry to provide these functions.

Printed Circuit Board manufacture will be required to integrate the required circuits into a small, neatly packed design in order to save space. A method for the production of this PCB will be selected from the ones available in the Senior Design Reference materials.

Task 2 Expected Results: Combining all Task 2 subtasks will deliver a new technology to the project that used to be unavailable.

3.3 Task 3 – End Product Design

Task 3 Objective: Design each component of the ultrasonic cleaning system so that it will clean as many records as possible without user intervention.

Task 3 Approach: Assess each area of the project that needs to be completed and provide a viable solution.

Subtask 3a – Physical Mounting of Records

The records will be held vertically on a metal spindle with rubber spacers inserted between them to provide adequate room for cavitation. The spindle will be a long metal rod should be able to hold a minimum of 1 up to as many records that can be cleaned efficiently. A method is required to hold the records in place so they rotate with the rotation of the spindle. The spindle may be notched or a compression spring used to push the records into the spacers. See Figure 4 below.

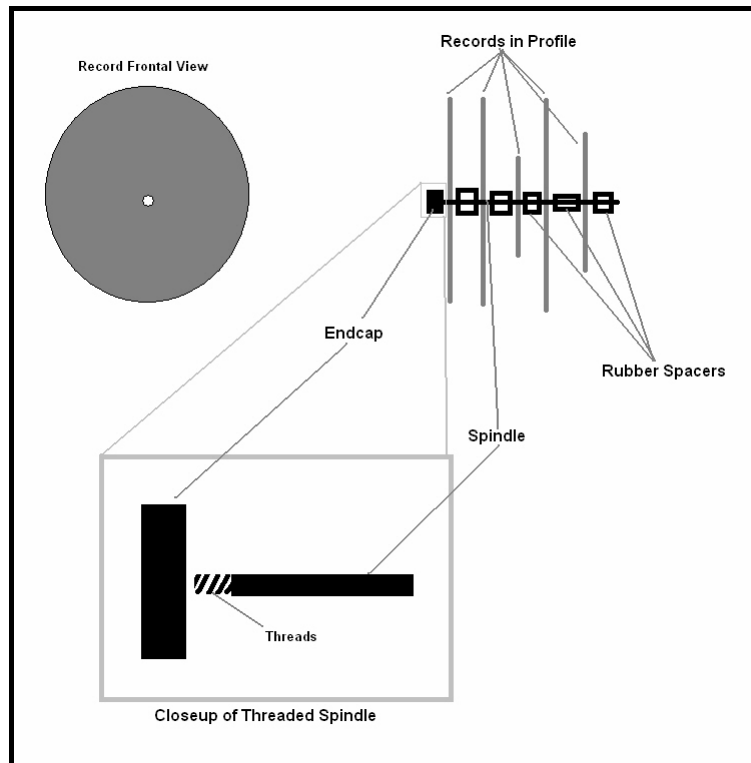

Initial Record Mounting and Spindle Design
[Figure 4]

The spindle will be attached to an arm which will be controlled by the automation system to lower and raise the records from the water. The arm may be physically weighted like an elevator or driven by a screw gear and a DC motor.

Subtask 3b – Design of Tank for Cleaning Bath

The tank must be large enough to accommodate as many records that will fit on the spindle as well as filtration equipment and the transducers if they are to be submerged (Figure 5). Testing of different placements of transducers will provide the final transducer placement. A tank will either be constructed of metal or fabricated from fiberglass to accommodate all of the necessary equipment as well as the record(s) to be cleaned.

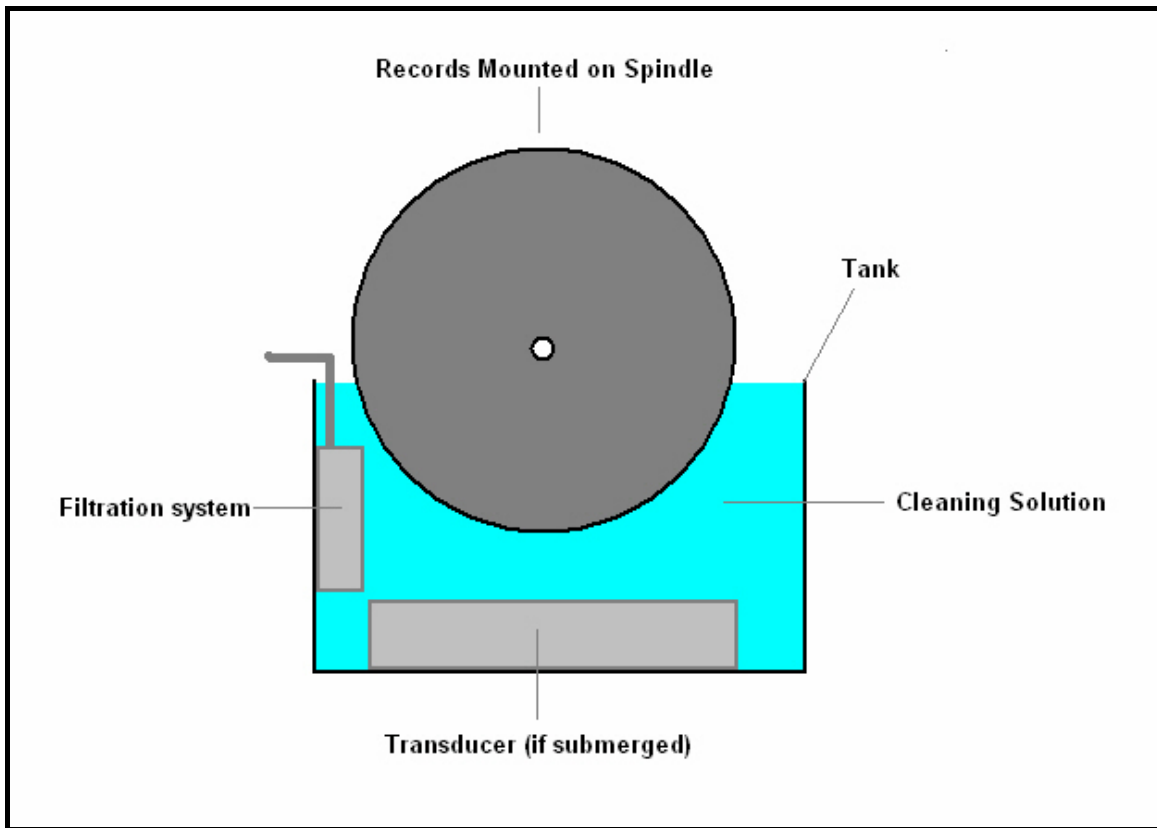

Initial Tank Design
[Figure 5]

Subtask 3c – Ultrasonic component

The ultrasonic component of the project consists of the transducer and its signal generator/power source.

An ultrasonic transducer converts electrical signal into analog ultrasonic sound which is used to create cavitation in the cleaning solution. The transducer(s) used for the project will be large in size and number to cause sufficient cavitation in the entire liquid bath. They will either be submerged or mounted on the bottom and/or sides of the tank in order to ensure proper coverage; see Figure 6.

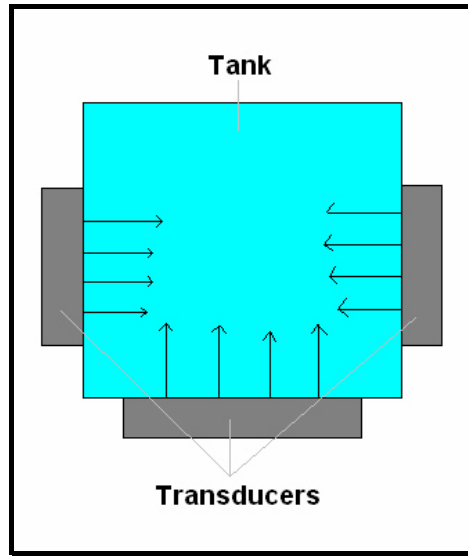

Placement of Transducers
[Figure 6]

The signal generator will control and supply the ultrasonic signal to the transducers. This segment of the design is important since commercially available signal/function generators are far from cost-efficient and offer too many unneeded features. Individual components would consist mainly of common resistors and capacitors as well as a custom PCB.

The signal generator will use a waveform generator IC package triggered by the microcontroller that also controls the automation. (Figure 7) Modulation and frequency are specified through the external configuration of resistors and capacitors.

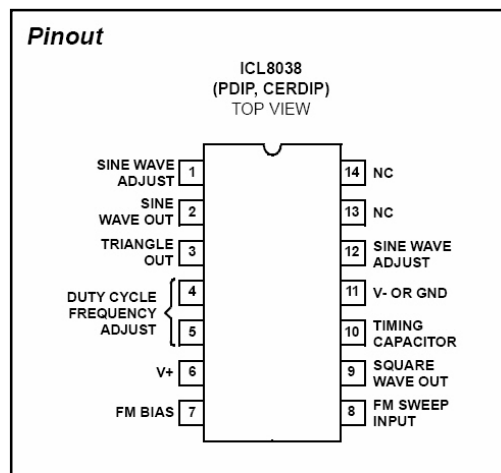

Example of an 8038 Waveform Generator Integrated Circuit from Intersil^[5]
[Figure 7]

See Figure 8 for an example of a circuit utilizing a 8083 waveform generator IC (noted as “IC1”) to create a selectable function generator.

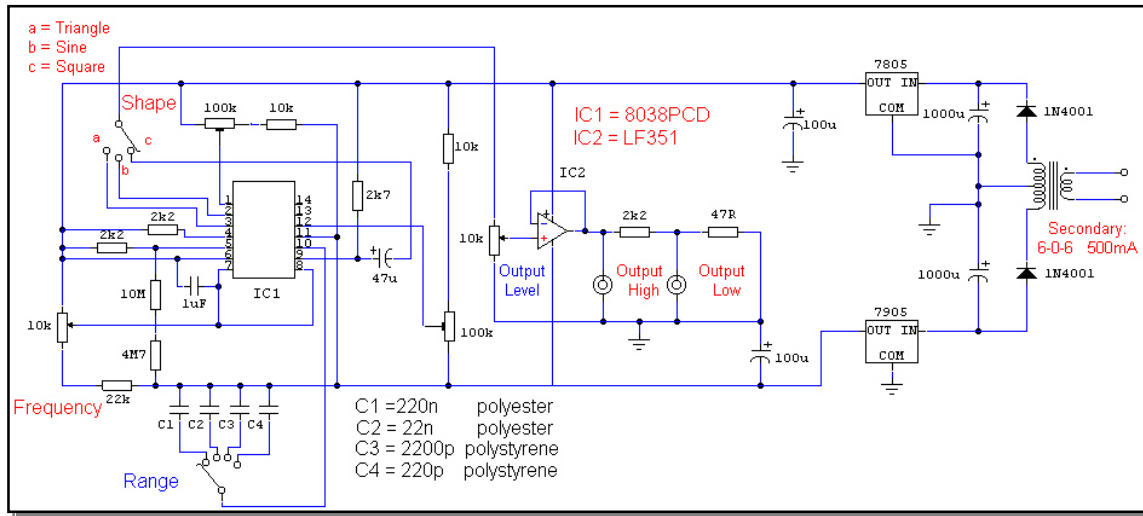

Example of Function Generator circuit utilizing a single 8083 IC from MIT^[6]
 [Figure 8]

The generator will also provide power to the transducers and must be designed around the requirements of the transducers selected for the design. It will receive DC voltage from the rectifier circuit.

Subtask 3d – Ultrasonic Cleaning Solution

The cleaning solution bath is important as it is the body of cavitation. Water is the base and a chemical is added from concentrate which is low cost. The solution must be able to hold the particulate matter that is to be cleaned from the record or else it will simply dry back on the record after cleaning. It may be hazardous to human contact and care must be taken for safety from the user. A proper solution depends on the frequency used, type of dirt to be cleaned, and material to be cleaned. Selection will be made by the team members based on research and/or testing.^[4]

Subtask 3e – Filtration

Filtration of the cleaning solution is needed to keep the dirt from reattaching to the records after cleaning. A simple, low-cost aquarium filter approach may be sufficient to remove particulate matter, but must be checked to appraise whether it would be robust and efficient. An electro-static method might be advantageous, but may be a safety hazard in conjunction with certain chemical solutions. Mounting a system would be achieved by placing it inside the bath (Figure 4), necessitating that it be able to withstand the cavitation of the cleaning process. Research is required to see which method would be more useful.

Subtask 3f – Automated Control

The automated control system will consist of a microcontroller, I/O devices for user interaction, and servos/motors to control operation of the system. The required actions are simple and the system will only need a simple low-cost microcontroller to be selected through research. Its functions are to handle the triggering of motors, the ultrasonic signal generator, and simple I/O devices. It will control the ultrasonic cleaning cycle through a simple timer whose duration will be set by the results of testing for the optimal time required for an acceptable clean. The timer may be set for a longer or shorter time, depending on the control input from the user. The microcontroller may also be used to control what frequency is being used for the ultrasonic cleaning.

The I/O devices include led indicators, a 7-segment led timer display, control buttons, switches to select intensity of cleaning process, and a panic button to interrupt the automation. The indicators will show if the unit is powered on and what automated process it is in. The 7-segment display will show the remaining time on the ultrasonic cleaning process. Control buttons may allow the user more interactive control by allowing he/she to select the record size, intensity of the clean, and what frequency to use for the ultrasonic cleaning process. A panic button is required so the user can halt the current process of the automation.

The motors control the rotation of the records and action of the spindle arm. Spindle rotation must be kept even and not too fast as to splash water on the record label. It may be desirable for the rotational speed to vary or be set by the user. The cleaning process for smaller records could be more effective if a slower speed is used since the grooves on a 45 are larger than that of a 33. The spindle arm will raise and lower the records from the bath and its motion must be smooth as to avoid damage to the mounted records. It must also be solid enough to support the weight of 10 full sized records.

Subtask 3g – Power Supply

Power is to be provided by a 60-cycle 115v AC signal from a common 3 prong outlet. The AC signal is to be converted to a DC voltage as specified by the microcontroller and other electrical system requirements. A transformer and bridge or similar rectifier design will be used.

(Figure 9 from <http://hyperphysics.phy-astr.gsu.edu/hbase/electronic/rectbr.html>)

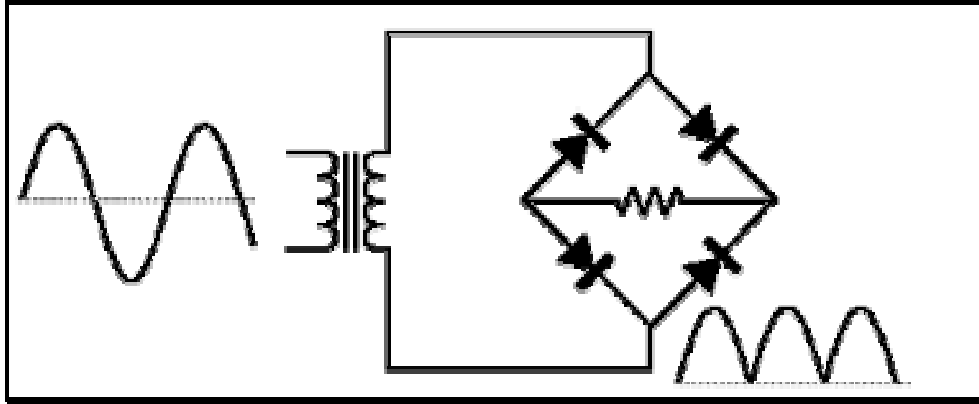

Example of a Simple Bridge Rectifier
[Figure 9]

Task 3 Expected Results: Combining all Task 3 subtasks an entire ultrasonic record cleaning system should be devised.

3.4 Task 4 – End-Product Prototype Testing and Implementation

Task 4 Objective: Make sure the project can complete its tasks successfully and find bugs or hazards in the project prototype and correct them before they reach the client.

Task 4 Approach: The prototype will be used as it normally will be when the end product is created. The prototype run through a battery of tests to make sure that it can complete all of its required tasks. Documentation will be kept the entire time the prototype is in testing to keep a log of any problems that should arise with the ultrasonic cleaner.

After extensive testing has been conducted, all problems that were found will be corrected or a different method shall be chosen so that the project will still be able to meet all of its requirements.

Task 4 Expected Results: When testing and implementation of the prototype have finished a complete and fully functional machine will be ready for final design. Thus all of the bugs have been worked out and it is basically ready for delivery to the client.

3.5 Task 5 – End-Product Documentation

Task 5 Objective: Create all of the documentation for the finished project including users manual, design report, and final report.

Task 5 Approach: The design report will be created before the project is built. It will facilitate as a guide to the project construction. The final report will be written after the project prototype is working and will encompass all of the tears and

tribulations that occurred during the design, construction, and testing. The users manual will be created for the use of the everyday user, making it easy for them to use the ultrasonic cleaner, even if they have never seen it before.

Task 5 Expected Results: A complete report on the ultrasonic cleaner, including design, troubleshooting, and implementation. As well as a users manual that will be able to facilitate in using and possible troubleshooting of the ultrasonic cleaner.

3.6 Task 6 - End-Product Demonstration

Task 6 Objective: Show a demonstration to client, faculty, and industrial review board.

Task 6 Approach: Team members familiar with the workings of the prototype will be assigned to its demonstration. Practice will take place to ensure a bug-free demonstration. The prototype will be demonstrated to the faculty advisors before it is shown to the client, review panel, or the public. The prototype will also be shown to the client before it is presented to the Industrial Review Panel. Once all stakeholders are satisfied with the prototype, it will be demonstrated to the Industrial Review Panel.

3.7 Task 7 – Project Reporting

Task 7 Objective: Accumulation of all of the project documentation and findings

Task 7 Approach: A project plan will be completed for the faculty advisors and client. A poster will be developed to highlight the project plan and ideal end-product. A report will be written describing the end-product design. An outline of all aspects of the project's development will be prepared at its completion. The team will send weekly progress reports to the faculty advisors and the client.

Task 7 Expected Results: This will effectively keep everyone on the team informed as to what is happening and keep a well documented record of the tasks the team performed.

4.0 Resources

The resources that will be needed to complete the project will be as follows. The most exhausting resource for this project is all of the man hours that will be required to complete the project. See Table 1.

Personel	Task 1	Task 2	Task 3	Task 4	Task 5	Task 6	Task 7	Task 8	Totals
Aswegan, Brad	5	35	40	40	30	10	20	35	215
Uhlenkamp Kenneth	4	25	35	45	20	5	20	60	214
Whitcomb Andrew	3	30	40	30	25	15	25	30	198
Wilcox Daniel	3	30	35	35	25	10	25	40	203
Totals	15	120	150	150	100	40	90	165	830

Estimated Personnel Effort Requirements (hours)
[Table 1]

Not only are there a lot of man hours put into the project but other resources have to be considered as well. These resources include the cost of the materials needed to design and build the project. See Table 2.

Item	Team Hours	Other Hours	Cost
Parts and Materials			
a. Ultrasonic Transducers	0	0	\$100.00
b. Records	0	0	Donated
c. Ultrasonic Cleaning Solution	0	0	\$30.00
d. Mechanical Components	0	0	\$30.00
e. Electronic Components	0	0	\$50.00
f. Poster Printing	16	0	\$50.00
Total	16	0	\$260.00

Other Required Resources
[Table 2]

Once all of the estimates have been thoroughly thought out and tabulated an idea for how much the entire project is going to cost can be put together. This is seen in Table 3.

Item	W/O Labor	With Labor
Parts and Materials		
a. Ultrasonic Transducers	\$100.00	\$100.00
b. Records	Donated	Donated
c. Ultrasonic Cleaning Solution	\$30.00	\$30.00
d. Mechanical Components	\$30.00	\$30.00
e. Electronic Components	\$50.00	\$50.00
f. Poster Printing	\$50.00	\$50.00
Subtotal	\$260.00	\$260.00
Labor at \$10.50 per hour		
a. Aswegan, Brad		\$2,257.50
b. Uhlenkamp Kenneth		\$2,247.00
c. Whitcomb Andrew		\$2,079.00
d. Wilcox Daniel		\$2,131.00
Subtotal		\$8,714.50
Totals	\$260.00	\$8,974.50

Original Project Estimated Costs
[Table 3]

5.1 Deliverables Schedule

A schedule is very important for the project to move along as needed. This is the schedule for the deliverable sections of the project. The deliverables schedule for Fall of 04 is in Figure 10 and the deliverables schedule for Spring of 05 is in Figure 11.

Task	Date	Dur	Aug	September				October					November				December			
				5	12	19	26	3	10	17	24	31	7	14	21	28	5	12	19	26
Project Plan																				
Unbound Project Plan	17-Sep	2w																		
Bount Project Plan	5-Oct	2w																		
Review Plan w/ Client		1d																		
Project Poster																				
Unbound Design Report	12-Nov	4w																		
Review Report w/ Client		1d																		
Bound Design Report	15-Dec	5w																		
Prototype																				
Prototype Delivered to Client for Testing	12-Mar	9w																		
Meet w/ Client to Review Prototype Performance		1d																		
Final Product w/ Documentation Delivered to Client	5-May	5w																		
Final Report																				
Unbound Final Report	1-Apr	5w																		
Review Report w/ Client		1d																		
Bound Final Report	5-May	5w																		
Industrial Review Panel Presentation																				
		2w																		

Fall 04 Deliverables Schedule
[Figure 10]

Task	Date	Dur	January				February				March				April				May		
			2	9	16	23	30	6	13	20	27	6	13	20	27	3	10	17	24	1	8
Project Plan																					
Unbound Project Plan	17-Sep	2w																			
Bount Project Plan	5-Oct	2w																			
Review Plan w/ Client		1d																			
Project Poster																					
Unbound Design Report	12-Nov	4w																			
Review Report w/ Client		1d																			
Bound Design Report	15-Dec	5w																			
Prototype																					
Prototype Delivered to Client for Testing	12-Mar	9w																			
Meet w/ Client to Review Prototype Performance		1d																			
Final Product w/ Documentation Delivered to Client	5-May	5w																			
Final Report																					
Unbound Final Report	1-Apr	5w																			
Review Report w/ Client		1d																			
Bound Final Report	5-May	5w																			
Industrial Review Panel Presentation																					
		2w																			

Spring 05 Deliverables Schedule
[Figure 11]

- Meeting w/ client
- Work in progress
- ▨ Break periods

5.2 Project Schedule

The actual project has a schedule of its own. This is a guideline for when different sections of the project need to be completed. The schedule for Fall of 04 is in Figure 12 and the schedule for Spring of 05 is in Figure 13 on the next page.

Task	Duration	Aug	September				October					November				December			
			5	12	19	26	3	10	17	24	31	7	14	21	28	5	12	19	26
Problem Definition																			
Problem Definition Completion	2w		■	■															
End User(s) and End Use(s)	2w		■	■															
Constraint Identification	2w				■	■													
Technology Considerations and Selection																			
Identification of Possible Technologies	5w		■	■	■	■	■												
Identification of Selection Criteria	2w				■	■													
Technology Research	4w						■	■	■	■									
Technology Selection	1w										■								
End-Product Design																			
Identification of Design Requirements	2w								■	■									
Design Process	6w										■	■	■	■	■	■			
Documentation of Design	6w															■	■		
End-Product Prototype Implementation																			
Identification of Prototype Limitations	2w																		
Implementation of Prototype End Product	8w																		
End-Product Testing																			
Test Planning	2w																		
Actual Testing	6w																		
Test Results Evaluation	1w																		
End-Product Documentation																			
Development of End-User Documentation	3w																		
Development of Maintenance Support Documentation	3w																		
End-Product Demonstration																			
Demonstration Planning	2w																		
Faculty Advisor's Demonstration	1w																		
Industrial Review Panel Demonstration	1w																		
Project Reporting																			
Project Plan	4w		■	■	■	■													
Project Poster	4w																		
Design Report	7w																		
Final Report	10w																		
Weekly Email Reporting			■	■	■	■	■	■	■	■	■	■	■	■	■	■	■	■	■

Fall 04 Project Schedule
[Figure 12]

- Meeting w/ client
- Work in progress
- ▨ Break periods

Task	Duration	January				February				March				April				May		
		2	9	16	23	30	6	13	20	27	6	13	20	27	3	10	17	24	1	8
Problem Definition																				
Problem Definition Completion	2w																			
End User(s) and End Use(s)	2w																			
Constraint Identification	2w																			
Technology Considerations and Selection																				
Identification of Possible Technologies	5w																			
Identification of Selection Criteria	2w																			
Technology Research	4w																			
Technology Selection	1w																			
End-Product Design																				
Identification of Design Requirements	2w																			
Design Process	6w																			
Documentation of Design	6w																			
End-Product Prototype Implementation																				
Identification of Prototype Limitations	2w																			
Implementation of Prototype End Product	8w																			
End-Product Testing																				
Test Planning	2w																			
Actual Testing	6w																			
Test Results Evaluation	1w																			
End-Product Documentation																				
Development of End-User Documentation	3w																			
Development of Maintenance Support Documentation	3w																			
End-Product Demonstration																				
Demonstration Planning	2w																			
Faculty Advisor's Demonstration	1w																			
Industrial Review Panel Demonstration	1w																			
Project Reporting																				
Project Plan	4w																			
Project Poster	4w																			
Design Report	7w																			
Final Report	10w																			
Weekly Email Reporting																				

Spring 05 Project Schedule
[Figure 13]

- Meeting w/ client
- Work in progress
- ▨ Break periods

If everything stays on schedule the group should not have a problem successfully completing the project.

6.0 Project Team Information

The project team is made up of four senior design students, two faculty advisors and one client. Contact information is very critical with the members of the team so they can be accessed in a timely manor when needed.

Client:

R.E. Patterson, III
326 Town Engineering
Ames, IA 50011-3230
Phone: 515-294-2428
Fax: 515-294-6760
repii@iastate.edu

Home: 515-232-9933

Advisors:

Dr. John Lamont
324 Town Engineering
Ames, IA 50011-3230
Phone: 515-294-3600
Fax: 515-294-6760
jwlamont@iastate.edu

Home: 515-292-5541

R.E. Patterson, III
326 Town Engineering
Ames, IA 50011-3230
Phone: 515-294-2428
Fax: 515-294-6760
repii@iastate.edu

Home: 515-232-9933

Team Members:

Brad Aswegan
Electrical Engineering
215 E. 7th St.
Ames, IA 50010
515-460-2218
baswegan@iastate.edu

Kenneth Uhlenkamp
Electrical Engineering
1424 Idaho Ave.
Ames, IA 50014
515-292-5939
712-790-3043
kuhlenka@iastate.edu

Andrew Whitcomb
Computer Engineering
3339 Friley Noble
Ames, IA 50012
515-572-5590
andw@iastate.edu

Daniel Wilcox
Computer Engineering
2517 Storm St.
Ames, IA 50014
515-292-8360
confused@iastate.edu

7.0 Summary

For the best possible musical experience audiophiles believe that vinyl records have the best representation of the original recording. This is only possible if the vinyl record is free of all contaminants that might inherently alter the sound that is created from the recording. With the delicate nature of vinyl records and the time consuming process of keeping them maintained a simple, effective, inexpensive, and automated solution must be found to return vinyl recordings to their original state.

An investigation of the best possible ways to clean vinyl recordings will be conducted. The results from the investigation will be used to evaluate the best possible way to clean vinyl records with as little user dependence as possible. Commercial options are currently available that complete such tasks but are very expensive. An affordable solution will be designed and tested.

Due to the current research it appears as though an automated ultrasonic cleaning machine will do the most effective job. Having it automated as possible is the main goal. Detection of the cleanliness of the record is anticipated so the machine will be able to run on its own and know when the cleaning of the record is done. This will allow audiophiles to keep their record collections in mint condition with little time and effort.

8.0 References

- 1 <http://www.positive-feedback.com/Issue9/images/v49.jpg>
- 2 “Fundamentals of Sonic Cleaning”
www.icknowledge.com/misc_technology/Megasonic.pdf
- 3 “Ultrasonic Cleaning”
<http://www.bluewaveinc.com>
- 4 “The Ins and Outs of Ultrasonic Cleaning”:
<http://www.healthsonics.com/houke.htm>
- 5 “ICL8038 Device Information”
<http://www.intersil.com/products/deviceinfo.asp?pn=ICL8038>
- 6 “Function Generator”
<http://www.mitedu.freeseve.co.uk/Circuits/Testgear/funcgen.htm>